

# BLANCO pendant - sospensione

Matteo Ugolini design

# SE322BB V11

news 2025

**A - LAMP** *corpo lampada* matt white aluminum - alluminio bianco opaco

**B - LAMPSHADE** *paralume* matt white aluminum - alluminio bianco opaco

**C - ELECTRICAL CABLE** *cavo elettrico* white 2 meters - 2 metri bianco

**R- CEILING CUP** *rosone* matt white aluminum - alluminio bianco opaco

**F- SUSPENSION CABLE** *fune* steel 2 meters - 2 metri acciaio

**OPTIONAL** *accessorio* power supply included - alimentatore incluso

**ELECTRICAL SYSTEM** *disp. elettrico* 23,8W, 700mA, 2893lm, 3000K

**PACKAGING** *imballo* 67x73x19 cm - 26,3"x28,7"x11,8"

**NET WEIGHT** *peso netto* 4 KG - 8,8 lbs





**GROSS WEIGHT** *peso lordo* 5,5 KG - 12,1 lbs

**IP RATE** *grado protezione* IP20

**CERTIFICATION** *conformità* IEC 60598-1:2020



**EMISSION** *emissione* unidirectional - unidirezionale

-  direct - diretta
-  filtered - filtrata
-  indirect - indiretta
-  none - assente

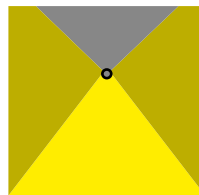

**DRY LOCATION**

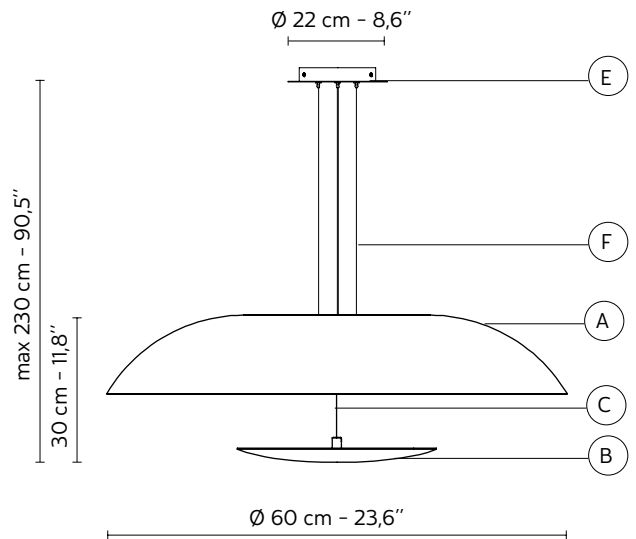

apparecchio fornito di sorgenti luminose di classe energetica E  
lamp equipped with light sources energy class E

