

LAMP *corpo lampada* mineral brown aluminium - *alluminio mineral brown*

ELECTRICAL CABLE *cavo elettrico* black 0,5 meters - *nero 0,5 metri*

ELECTRICAL SYSTEM *disp. elettrico* LED CC 350mA, 2,9W, 471 lm, 3000K

OPTIONAL *accessorio*
*4W power supply - *4W alimentatore* **AC211AIV1E**
ground fastening - *attacco a terra* **AC313ATV1E**
fixing plate - *piastra di fissaggio* **AC313APV1E**





PACKAGING *imballo* 15x15x135 cm

NET WEIGHT *peso netto* 1,8 KG

GROSS WEIGHT *peso lordo* 3,3 KG

CERTIFICATION *conformità* IEC 60598-1:2020

EMISSION *emissione* unidirectional - *unidirezionale*

-  direct - *diretta*
-  filtered - *filtrata*
-  indirect - *indiretta*
-  none - *assente*

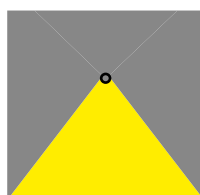

WET LOCATION

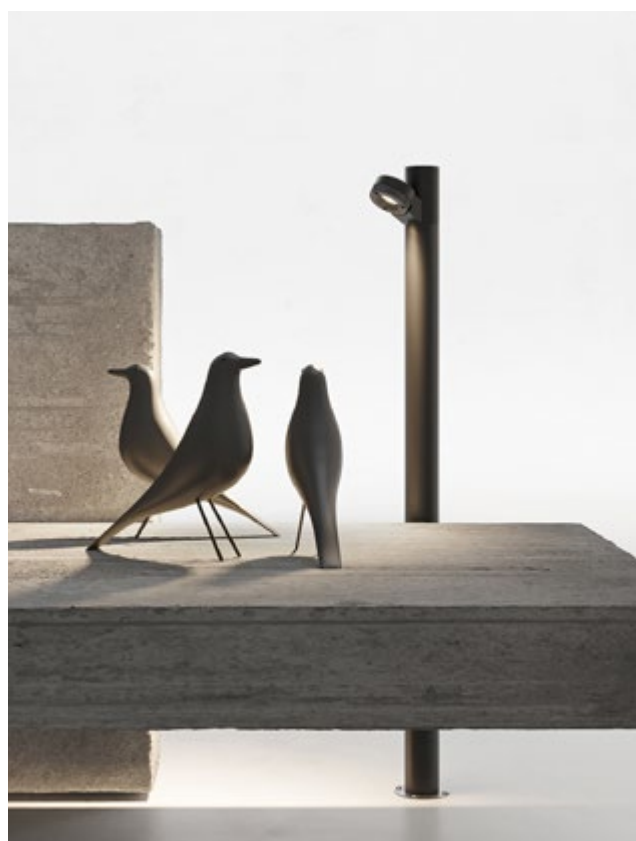
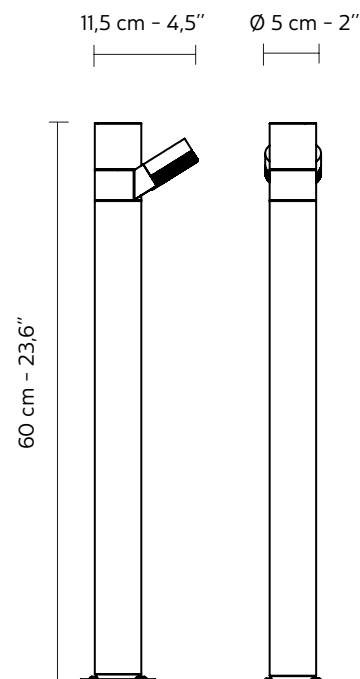

BEWARE: Extra low voltage lamp, power supply necessary
ATTENZIONE: Lampada bassissima tensione, necessario alimentatore